



Series Compensators With Hysteresis Control: A Reliable Solution For Voltage Sag Mitigation

Dr. Narendra Kumar Yegireddy Professor, EEE department, Lendi Institute of Engineering and technology, Vizianagaram, Andhra Pradesh, India.
narenyegireddy@gmail.com

Dr. Gottapu Santosh Kumar Department of Civil Engineering, Gayatri Vidya Parishad College of Engineering, Visakhapatnam, Andhra Pradesh, India.

Dr. M N V S S Kumar Associate Professor, Department of Electronics and Communication Engineering, Aditya Institute of Technology and Management, Tekkali, Srikakulam, Andhra Pradesh, India.

Budumuru Rajesh Professor, Department of MBA, Aditya Institute of Technology and Management, K.Kotturu, Tekkali, Andhra Pradesh, India.

Abstract:

Voltage sag is a pervasive issue in power systems, demanding effective solutions. Among the key technologies employed to combat voltage sags, the Dynamic Voltage Restorer (DVR) stands out. Positioned in series between the power source and the load, the DVR plays a vital role in mitigating voltage sags. To maximize its effectiveness, various compensating methods are available, including the pre-sag method, in-phase method, and in-phase advance compensation. One crucial aspect of DVR operation is the synchronization of the injected voltage with the phase of the supply voltage. This synchronization is pivotal for the DVR to accurately and swiftly compensate for voltage sags caused by short-circuit currents. To achieve this synchronization, the work described here employs the Discrete Fourier Transform (DFT) for phase detection, a critical step in DVR operation. Furthermore, the control strategy plays a significant role in the DVR's ability to mitigate voltage sags effectively. In this project, the hysteresis control technique is combined with Proportional-Integral (PI) control, and the results are compared with those obtained from a Proportional-Integral-Derivative (PID) controller. This comparative analysis provides valuable insights into the performance of these control strategies and their effectiveness in enhancing power quality by rectifying voltage sags. The findings of this study contribute to the optimization of DVR systems, offering improved voltage sag mitigation in power distribution networks.

Keywords: Voltage Sag Mitigation, Dynamic Voltage Restorer (DVR), Hysteresis Control, Discrete Fourier Transform (DFT)

1. Introduction

Traditionally, the mitigation of harmonic distortions and the provision of reactive power (VAR) compensation in electrical systems have often relied on the utilization of multi-pulse inverters, such as 6-pulse or 12-pulse configurations. These setups consist of several voltage-source inverters interconnected through a zigzag arrangement of transformers [1]. While effective, this approach has several drawbacks:

1. **Costly Transformers:** Transformers are the most expensive components in this system, significantly driving up the overall expenditure.
2. **High Losses:** Approximately 50% of the total losses in the system are attributed to these transformers, impacting system efficiency.
3. **Large Footprint:** The physical footprint occupied by these transformers constitutes around 40% of the entire system, making efficient land use a challenge.
4. **Control Challenges:** Control issues arise due to DC magnetizing and surge overvoltage problems stemming from transformer saturation.
5. **Reliability Concerns:** The transformers' reliability can be a point of concern, necessitating regular maintenance and posing operational risks.

To address these limitations, Pulse Width Modulated (PWM) inverters with high switching frequencies (e.g., 10 kHz) have been explored for harmonics and VAR compensation [2,3]. However, while they offer advantages in terms of size and efficiency, their high initial and operational costs have hindered their widespread adoption in power distribution systems.

Within the realm of power quality concerns, voltage dips have surfaced as a prominent issue. These transient occurrences manifest as momentary reductions in the root-mean-square (r.m.s) voltage magnitude, typically spanning a duration of 10 milliseconds to 1 minute. Voltage dips are chiefly characterized by two vital parameters: their depth (magnitude) and duration. The magnitude of a voltage dip can fluctuate within the range of 10% to 90% of the nominal voltage, corresponding to remaining voltage levels between 90% and 10% [4]. These dips can persist for durations ranging from half a cycle to a minute, exerting an impact on both phase-to-ground and phase-to-phase voltages within three-phase systems.

Voltage dips are often caused by various factors, including faults in the utility grid, internal faults within a customer's facility, or sudden surges in load currents, such as motor startups or transformer energization [5]. Common fault scenarios involve single-phase or multiple-phase short circuits, resulting in elevated currents. These high currents lead to voltage drops across the network impedance, causing a near-zero voltage in the faulted phases while the non-faulted phases remain relatively stable. Addressing voltage

dips is crucial for maintaining power quality and ensuring the uninterrupted operation of sensitive equipment in electrical systems [6].

2. Voltage Sag

Voltage dips represent one of the most prevalent power quality challenges encountered in modern electrical systems. These dips are characterized by a sudden and short-lived reduction in the root-mean-square (RMS) voltage magnitude, which, despite their brevity, can lead to significant disturbances in the system.

Defining a voltage sag is not always straightforward, with the concept often relying on just two defining parameters: depth or magnitude and duration. Voltage sags manifest as reductions ranging from 10% to 90% of the nominal voltage, corresponding to residual voltage levels of 90% to 10% [7]. These dips typically endure for a duration greater than half a cycle but less than 1 minute. The majority of voltage dips fall within the range of 4 to 10 cycles in duration, and they leave the system with a residual voltage of approximately 84% to 90% of the nominal voltage.

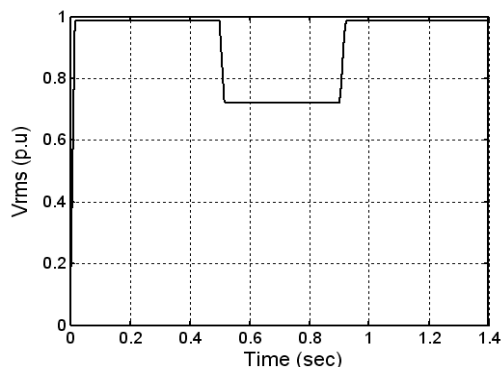

Fig 1. RMS waveform of Voltage sag

The severity of voltage sags, whether balanced or unbalanced, can be exacerbated by various factors and fault types [8]. When a sag event occurs, and the phase voltages deviate in magnitude or phase relationships from the expected 120 degrees, it falls under the classification of an unbalanced sag. It's worth noting that the specific characteristics of voltage sags in each phase of a three-phase system are influenced by factors such as the type of fault, transformer connections, and the equipment involved.

In the context of three-phase loads, voltage sags are categorized into seven distinct types, designated as A, B, C, D, E, F, and G [9]. Each of these types is associated with unique features and origins, reflecting the diverse range of factors that can contribute to voltage dip occurrences in electrical systems. An in-depth understanding of these classifications is crucial for effectively addressing and mitigating voltage sag-related issues within power distribution networks [10].

3. Power Quality

The industry faces substantial financial losses primarily attributed to power quality issues, including sags, short-term interruptions, and unwanted voltage waveform distortions. A significant concern for electricity consumers centers around the reliability of their power supply, defined here as the continuity of supply.

Challenges within the domain of distribution lines can be broadly classified into two primary categories: power quality and power reliability. The first category encompasses issues such as harmonic distortions, impulses, and voltage swells, while the second pertains to concerns like voltage sags and outages. Among these challenges, voltage sags stand out as particularly significant, as they have the potential to cause extensive damage. When a sag persists for more than a few cycles, it can disrupt the operation of control systems for motors, robots, servo drives, and machine tools.

Transmission lines are exposed to the unpredictable forces of nature, and each transmission line has inherent limitations in terms of load capacity. These limitations are often defined by stability constraints, thermal restrictions, or dielectric considerations. While power quality issues are frequently associated with the distribution side of the grid, it's important to recognize that transmission lines can significantly impact the quality of delivered power. Notably, many issues within the transmission system arise from natural forces or the interconnections between power systems, but individual customers also contribute to the challenges affecting power distribution systems.

The rapid advancements in power electronics technology offer exciting opportunities for the development of novel power system equipment, enhancing the utilization of existing systems. Since the 1990s, a range of devices falling under the category of Flexible AC Transmission Systems (FACTS) technology have been proposed and implemented. FACTS devices prove highly effective in various aspects, including power flow control, load sharing among parallel corridors, voltage regulation, improvement of transient stability, and mitigation of system oscillations. By providing added flexibility, FACTS controllers enable transmission lines to operate closer to their thermal limits. It's important to emphasize that FACTS serves as an enabling technology, working in conjunction with traditional mechanical switches rather than replacing them outright.

4. Voltage Source Inverter

Multilevel inverters have emerged as a topic of immense interest within the power industry, introducing a set of capabilities ideally suited for applications in reactive power compensation. One of their primary advantages lies in their capacity to facilitate the creation of high-power, high-voltage inverters. This ability is a result of the controlled distribution of device stresses within the multilevel structure. An increase in the number of voltage levels within the inverter doesn't mandate higher individual device ratings; instead, it elevates the overall power rating. The distinctive design of multilevel voltage source inverters excels in delivering high voltages while maintaining minimal harmonics, all achieved without the need for transformers or series-connected synchronized-

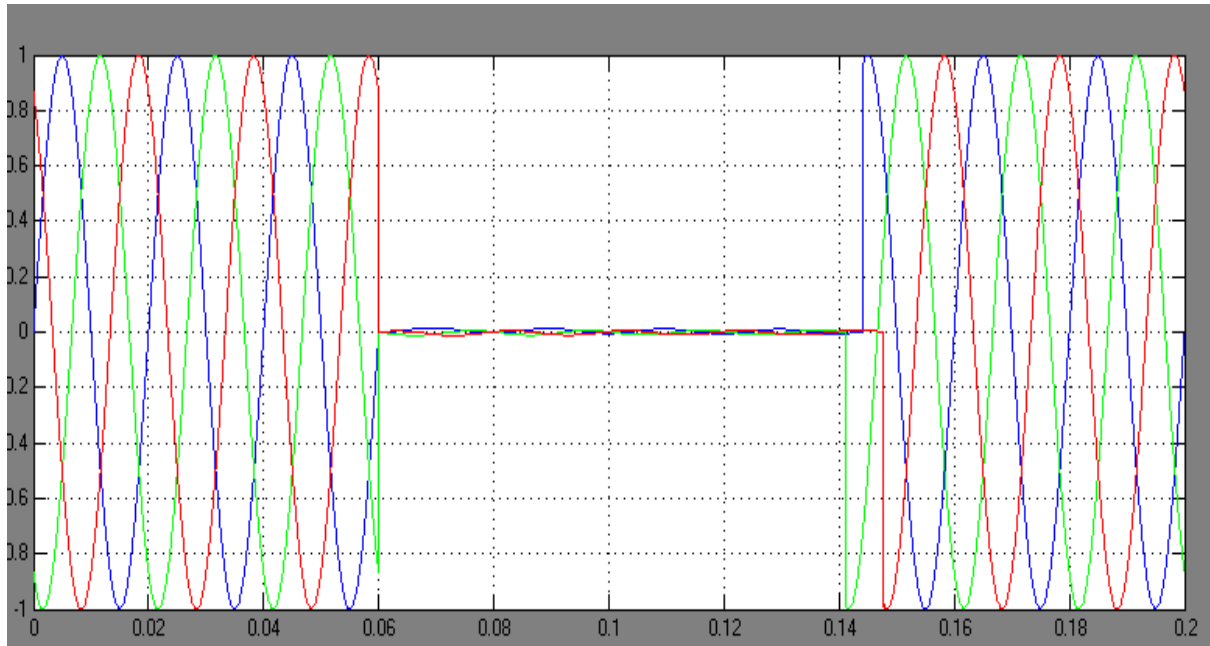

Fig 3. Voltage Across Inductive Load in Uncompensated Line

After applying compensation techniques, the output waveforms are rectified as shown in the results.

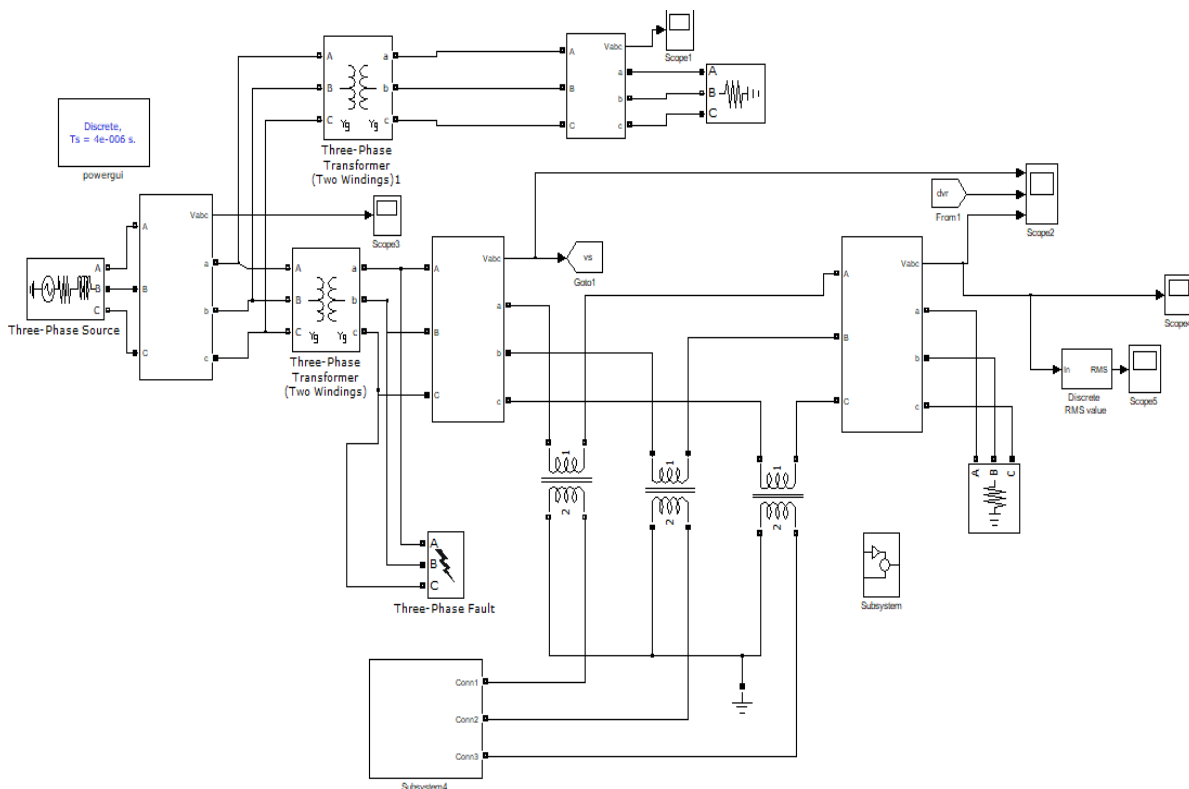

Fig 4. Simulation model of Compensated Transmission line

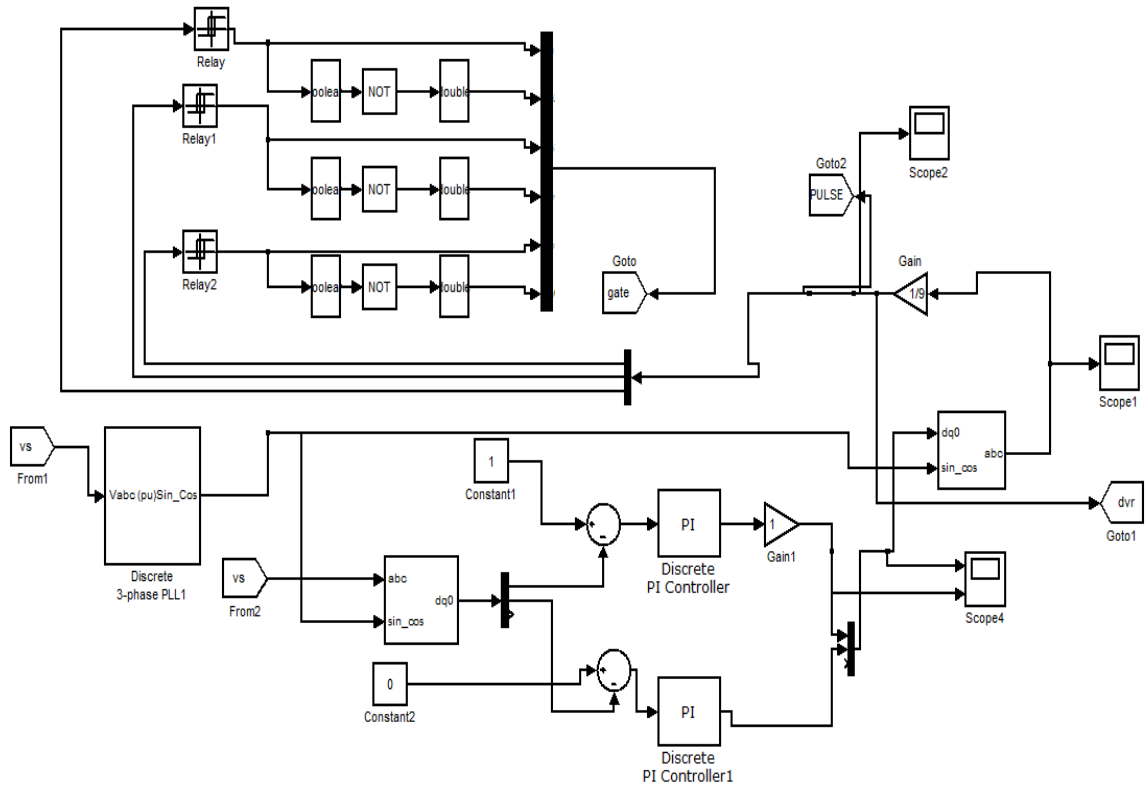

Fig 5. Hysteresis control applied in PI Controller

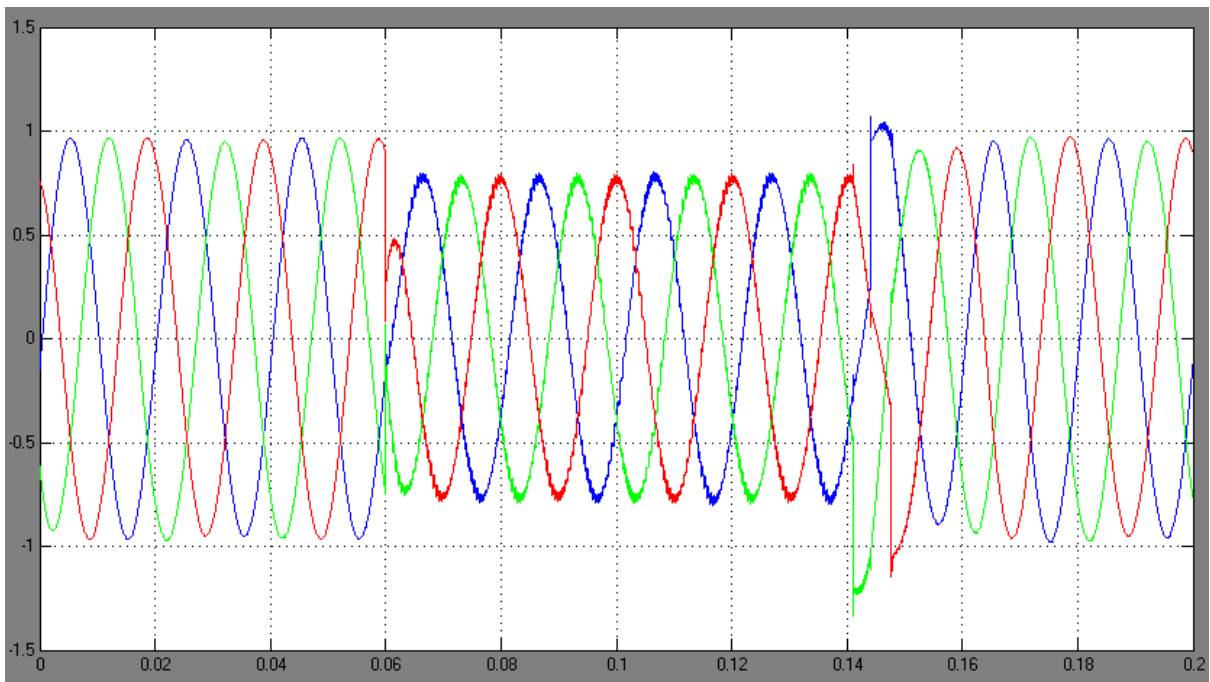

Fig 6. Voltage waveform after compensation with Hysteresis based PI Controller

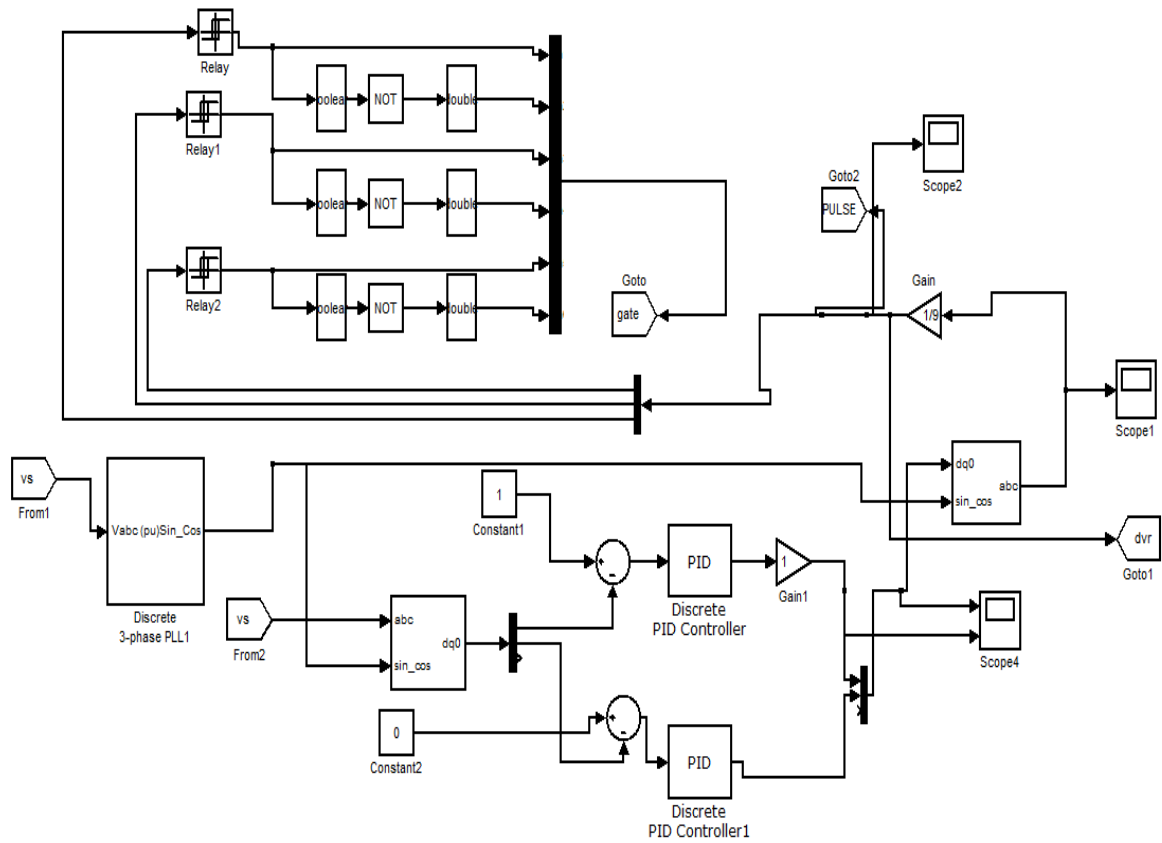

Fig 7. Hysteresis control applied in PID Controller

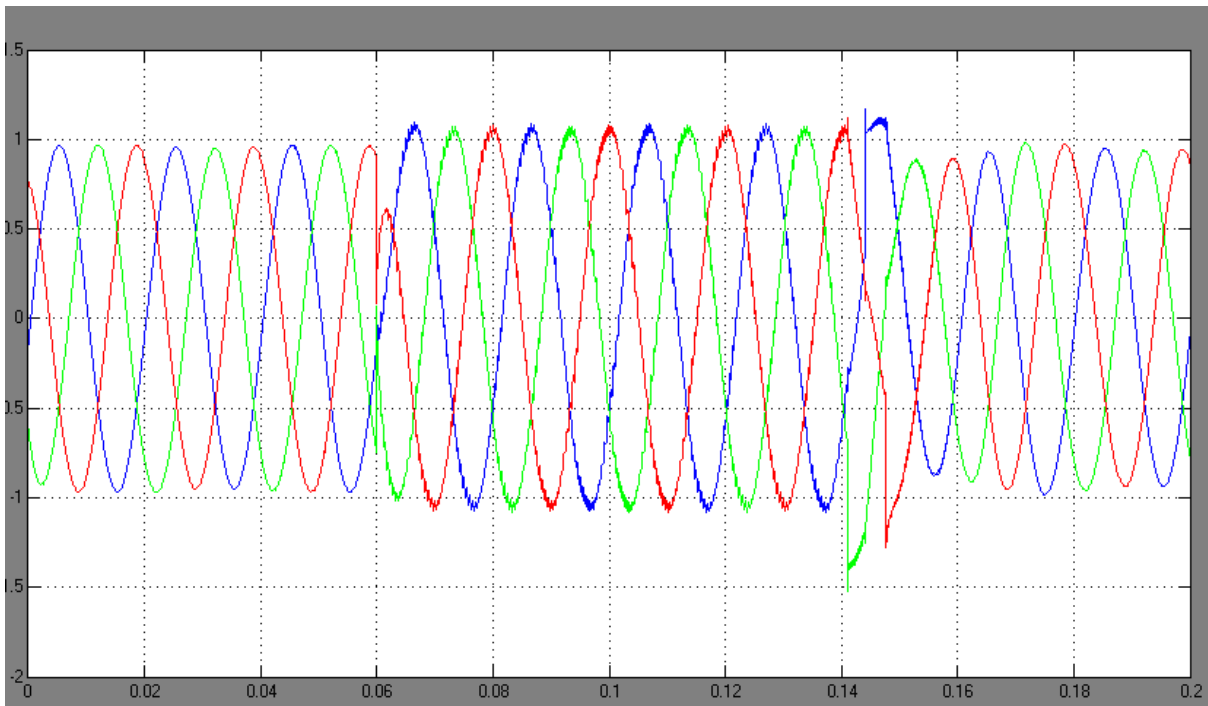

Fig 8. Voltage waveform after compensation with Hysteresis based PID Controller

The final comparison between the results is summarized in Table 1.

Table 1

	Uncompensated	Hysteresis using PI	Hysteresis using PID
Voltage Magnitude	Reduced to zero due to three-phase fault	80% Compensation	100% Compensation

6. Conclusions

In conclusion, this paper has provided an extensive model of a custom power device, the Dynamic Voltage Restorer (DVR), using the instantaneous P-Q theory. The control algorithms employed for the DVR have been thoroughly examined, particularly in the context of linear loads. Through simulation results, these control schemes have been illustrated in detail.

One noteworthy aspect of the control scheme is its ability to maintain power balance at the Point of Common Coupling (PCC) while regulating the DC capacitor voltages. The use of Pulse Width Modulation (PWM) control, which relies solely on voltage measurements, enhances its suitability for low-voltage custom power applications. Furthermore, extensive testing under a wide range of operational conditions has demonstrated the robustness of this control scheme in all scenarios.

The paper's key finding suggests that the implementation of a Dynamic Voltage Restorer (DVR) with Hysteresis-based Proportional-Integral-Derivative (PID) controllers yields superior results. This conclusion underscores the effectiveness and reliability of such control strategies in enhancing power quality and addressing voltage disturbances in electrical systems.

References

- [1] A. Sannino and J. Svensson, "Static series compensator for voltage sag mitigation supplying nonlinear loads," 2002 IEEE Power Engineering Society Winter Meeting. Conference Proceedings (Cat. No.02CH37309), doi: 10.1109/pesw.2002.985189.
- [2] P. Wang, N. Jenkins, and M. H. J. Bollen, "Experimental investigation of voltage sag mitigation by an advanced static VAr compensator," IEEE Transactions on Power Delivery, vol. 13, no. 4, pp. 1461–1467, 1998, doi: 10.1109/61.714772.
- [3] Omar, "New Control Technique Applied in Dynamic Voltage Restorer for Voltage Sag Mitigation," American Journal of Engineering and Applied Sciences, vol. 3, no. 1, pp. 42–48, Jan. 2010, doi: 10.3844/ajeassp.2010.42.48.
- [4] "Comparative Studies of Control Technique in Dynamic Voltage Restorer for Power Quality Improvement," International Journal of Science and Research (IJSR), vol. 4, no. 11, pp. 410–414, Nov. 2015, doi: 10.21275/v4i11.nov151155.

- [5] A. Ghosh, "Modelling and control of thyristor-controlled series compensators," IEE Proceedings - Generation, Transmission and Distribution, vol. 142, no. 3, p. 297, 1995, doi: 10.1049/ip-gtd:19951742.
- [6] A. Griffo and D. Lauria, "Control Lyapunov Function for Series and Parallel Compensators with Energy Storage Capabilities," International Journal of Emerging Electric Power Systems, vol. 9, no. 5, Nov. 2008, doi: 10.2202/1553-779x.1968. [Online]. Available: <http://dx.doi.org/10.2202/1553-779x.1968>
- [7] H. de Battista and R. J. Mantz, "Harmonic series compensators in power systems: their control via sliding mode," IEEE Transactions on Control Systems Technology, vol. 8, no. 6, pp. 939–947, 2000, doi: 10.1109/87.880597. [Online]. Available: <http://dx.doi.org/10.1109/87.880597>
- [8] G. Webb, A. Kurdila, and D. Lagoudas, "Adaptive Hysteresis Model for Model Reference Control with Actuator Hysteresis," Journal of Guidance, Control, and Dynamics, vol. 23, no. 3, pp. 459–465, May 2000, doi: 10.2514/2.4551.
- [9] A. K. MAHALANOBIS and A. K. NATH, "On the Compensation of Hysteresis Effects in Relay Control Systems by using Positive Hysteresis†," Journal of Electronics and Control, vol. 17, no. 6, pp. 683–695, Dec. 1964, doi: 10.1080/00207216408937739.
- [10] S. K. Saha, "Reliability Contingency Analysis by Static Synchronous Series Compensator in Optimal Power Flow," International Journal of Computer and Electrical Engineering, pp. 908–911, 2010, doi: 10.7763/ijcee.2010.v2.250.