



---

# Smart Shelf Using Internet Of Things

V.Lalitha<sup>[1]</sup>, Sneha Srikanth<sup>[2]</sup>, Sophia Rachel.J <sup>[3]</sup>, S.Subramanian <sup>[4]</sup>

1 Associate Professor ,Department of Computer Science and Engineering ,Sri Sai Ram Engineering College

2,3 Department of Computer Science and Engineering , Sri Sai Ram Engineering College , Chennai- 600 044.

4 Software Development Engineer ,Amazon , India.

---

## ABSTRACT

Smart shelves, the electronically connected shelves which can automatically monitor the shelf of the inventory in a retail establishment is one of the most feasible solutions to address the 'out of stock' items in physical stores A smart shelf is a shelf in a store that has been equipped with the ultrasonic sensors, a device that can measure the distance between the shelf and the product by using sound waves and the level of stock can be viewed in retailer application. A microprocessor is installed on the shelf for data processing Android applications for supplier and retailer are developed. Using this android application notifications are sent or received from microcontroller. Automatic replenishment alert is one of the most potential uses of smart shelves in the retail business area. The smart shelf notices when it's running out of an item and sends an alert to the back-end system. Depending on the system application of the store, the alert is either sent to the backroom or to a mobile computer, so that sales personnel can replenish the shelf or make order for more items.

## General Terms

Ultrasonic sensor, LCD display Arduino Uno, Monitoring stock, Android Application.

**Keywords** Internet of Things (IoT), Stock Awareness, Sensor Network, Replenishment alert

## 1. INTRODUCTION

In embedded systems the current worldwide trend is ubiquitous computing. It enables communication between everyday objects by embedding microprocessors in everyday

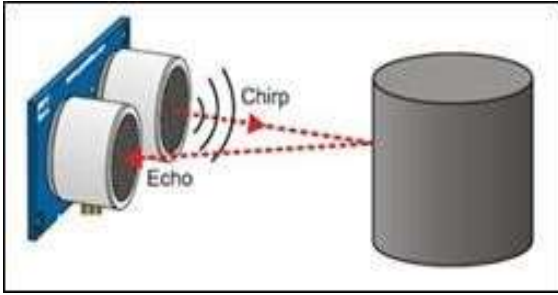

objects to make our life simpler. This particular idea revolves around sensing the load of the shelves thereby detecting the level of stocks and transmitting it to user's mobile device. We extend this concept to solve everyday problems like forgetting purchase of a particular grocery item. Devices like smart phones and wearables keep us reachable, interactable and updated to the everyday events happening around the world. We target to embed a mind in shelves, utilizing sensor and smart phone technology an automated to buy list is generated. To implement such a system, there is the need to continuously fetch, elaborate, and analyze data deriving from smart objects. This is achieved by the use of Sensor Networks, consisting of Arduino Uno along with HC-SR04 ultrasonic sensor interface. An ultrasonic sensor is used to read the level of goods on a shelf which uses the time of flight of an ultrasonic pulse to determine the distance.

It has 4 pins: GND, VCC, Trigger and Echo. Trigger and Echo are connected to the ESP8266 GPIO pins 12 and 13 respectively. A drawback with this ultrasonic sensor is that it operates off 5V, which is more than the 3.7 – 4.2 V Li-Ion battery can supply.



### Problem Statement

To develop a pervasive system to which senses the level of stocks and shares this information with users mobile device to generate alerts.

## 2 LITERATURE SURVEY

Issues that arise in retail store like out of stock are a major concern for Consumer Packaged Goods and Retail organizations. They lose billions of dollars every year. If items of interest are not available on the shelves, most of the customers buy from somewhere else and others buy a different brand.

[1] Describes how the shelves at a retail store can be made smarter such that they can raise alerts to restock themselves. Alerts to workers in retail shop can skip manual checks and alerts to CPG companies can accelerate refill if retailers do not maintain the right quantity or restock within Service Level Agreement (SLA). Using load sensors have been the most common practice yet it has not succeeded as anything else on the shelves still meant available. Thus the

challenges we face are to track not only the quantity but also the right brand, right variant in the right position with right visibility to shoppers on the right shelf. Internet of Things can help make this thing (shelves) smarter to required extent. The authors have enabled shelves to take its own selfie using a simple camera and then the images processing algorithms takes care of performing required analytics and generate alerts with the person responsible. This solution scores higher over other hardware and capital intensive IoT solutions being worked upon.

[2] In pervasive retail, ultrasonic sensor- enabled smart shelves are becoming common place. Real-time information about the items stock and location is provided by these devices, that being fact, few efforts have been made to reliably detect human interaction with the items. Novel approach is presented by author on real-time human object interaction detection. This approach is based on HC-SR04.

[3] The surge in the number of internet users and how the internet of things phenomena is affecting human lives. Home automation has immense impact and usage. The future of computing deals with embedding the sensors etc with the everyday use devices, the encompass several domains such as e- Governance, health care, Transportation, Waste Management, Food Supply Chains, and Energy and Utilization. Different labs such as iDorm, Smart home Monitoring etc. Also ambient intelligence is planted to at home to get the detail information about the people living.

[4] In pervasive retail, ultrasonic sensor- enabled smart shelves are becoming common place. Real-time information about the items stock and location is provided by these devices, that being fact, few efforts have been made to reliably detect human

interaction with the items. Novel approach is presented by author on real-time human object interaction detection. That approach is based on HC-SR04 using supervised machine learning techniques. After analyzing specific features of HC-SR04 human interaction with the smart shelf has been studied and more than 84% efficiency is noted.

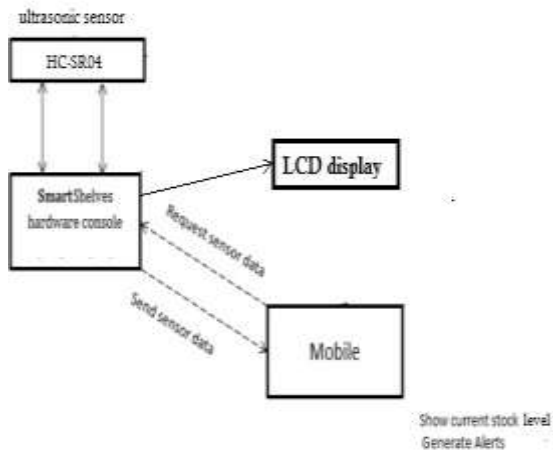

[5] WSN is of utter importance in IoT. WSNs bring IoT applications richer capabilities for both sensing and actuation. WSN solutions already have a wide range of applications, and research and technology advances continuously expand their application field. This trend also increases their use in IoT applications for versatile low-cost data acquisition and actuation.

[6] Kitchen is a very essential place of a home and cooking is one of the day to day activities. The usual difficulty in a kitchen during cooking is finding the items that are exhausted. The extensive use of automated systems indicates the demand of the household devices to be smart and automated to support us in our daily activities. The kitchen is one ideal place where automation at various levels can be done.



[7] An exploratory research project named “Smart Tupperware” conducted in Personal Task Assistants (PTA) is examining both devices and user interfaces for personal augmentation systems that can assist in such tasks as repeatedly maintaining kitchen foodstuffs inventory and integrating it with a shopping list application. Through sensor built in kitchen containers and various mnemonic methods, the system measures the fill status of the containers and maintains a distributed database that is uploaded to a personal device that is network-connected and user aware.

### **3 SYSTEM ARCHITECTURE**

The overall system design consists of following major modules:

- (a) Hardware
- (b) Mobile Device Figure

The Hardware module uniquely identifies the containers using Arduino Uno, LCD display and HC-SR04, senses distance to the items in the shelf and transmits data to mobile device when requested. The Mobile Device Requests hardware for sensor data, Performs operations on data, makes it available to the user, Generates alerts on low stock.

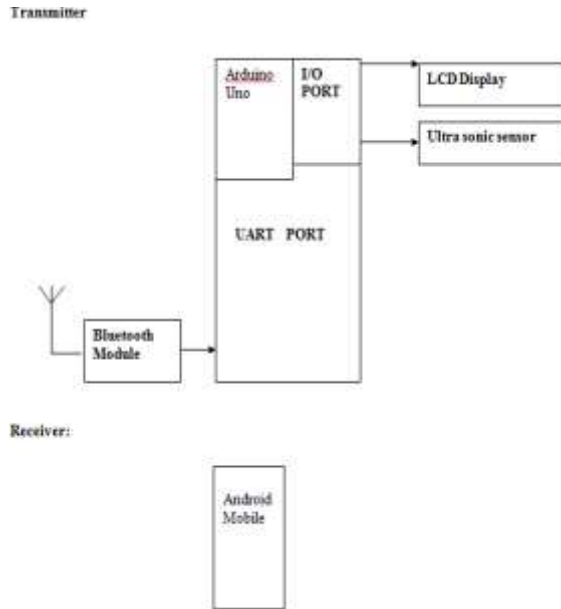

## 4 EVALUATION OF SYSTEM

### Advantages

The system provides access to authorized persons only. It generates alerts based on exhaustion of stocks. This system is real time and user friendly.

### Disadvantages

The seamless working of the product largely depends upon the network signal quality. Calibration of the ultrasonic sensors can be a deployment time overhead. Also the system is expensive to scale up.

### Applications

This idea can be used extensively in industry where the raw materials are supplied just in time, hospitals where the level of medicine stock is critical or hotel management industry where physically monitoring the stocks is tedious.

## 5 CONCLUSIONS

Thus the system provides easy monitoring of stock inventory by using load sensors,

Arduino Uno, HC-SR04, Bluetooth and a mobile device application providing significant advantages like availability of real-time sensor data on users' mobile device, easy to use and set up application, implicit analysis of fetched data and generating alerts based on the same, prediction of data using machine learning etc. Although, this approach comes with a few disadvantages like overhead of calibrating ultrasonic sensors or expensive to scale up, the idea of sensing quantity of stock using load sensors and making it implicitly available to the users can be extensively used in

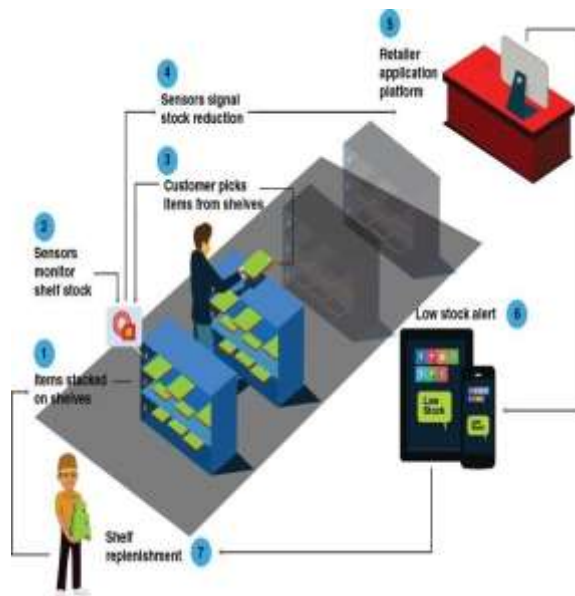

manufacturing industry where stocks of raw material are tedious to monitor or if unexpected exhaustion of a particular raw material halts the manufacturing process. In this approach the devices are networked which is an attribute of poor level ubiquity. It can further be improved to be choreographed.

## 6 FUTURE ENHANCEMENTS

In future the project can be extended by the additional use of RFID (Radio Frequency Identification) tags to check for misplaced items and slippage of expiry dates and HX711 load cell for weight monitoring. The sales data that has been collected from the shelves can be analyzed with the help of supervised machine learning and produce business insights. The system can be designed to send automated orders directly to central warehouses or manufacturer

## 7. REFERENCES

- [1] International Journal of Computer Applications (0975 – 8887) Volume 157 – No 9, January 2017 Design and Implementation of Stock-Aware Shelves using Pervasive Computing
- [2]Rakesh Satapathy, Srikanth Prahlad, Vijay Kaulgud, “Smart Shelfie Internet of Shelves For higher on-shelf availability”, 2015 IEEE Region 10 Symposium
- [3]Sean Dieter Tebje Kelly, Nagender Kumar Suryadevara, and Subhas Chandra Mukhopadhyay, Fellow, IEEE, “Towards the Implementation of IoT for Envi- ronmental Condition Monitoring inHomes”,IEEE SENSORS JOURNAL, VOL.13, NO. 10, OCTOBER 2013
- [4]Paolo Bellavista, Senior Member, IEEE, Giuseppe Cardone, Member, IEEE, An- tonio Corradi, Member, IEEE, and Luca Foschini, Member, IEEE,“Convergence of MANET and WSN in IoT Urban Scenarios”, IEEE SENSORS JOURNAL, VOL. 13, NO. 10, OCTOBER 2013
- [5]Mihai T. Lazarescu,“Design of a WSN Platform for LongTerm Environmental Monitoring for IoT Applications ”,IEEE , MAY 2013 Carla R. Medeiros, Jorge R. Costa, Member, IEEE, and Carlos A. Fernandes, Senior Member, IEEE,“RFID Smart Shelf With Confined Detection Volume at UHF”,IEEE ANTENNAS AND WIRELESS PROPAGATION LETTERS, VOL. 7, 2008
- [6]Karuppiah Pal Amutha, Chidambaram Sethukkarasi, Raja Pitchiah, “Smart Kitchen Cabinet for Aware Home ”,SMART 2012 : The First International Con- ference on Smart Systems, Devices and Technologies
- [7]Richard Voyles, Jaewook Bae, Bret Smith, David Kusuma and Ledu Nguyen,“Smart Tupperware: Active Containers for Kitchen Automation”SICE Annual Conference 2008